

RANGER DRAINAGE DISTRICT

LOT GRADING GUIDELINES FOR CITY LOTS WITHIN DRAINAGE DISTRICT

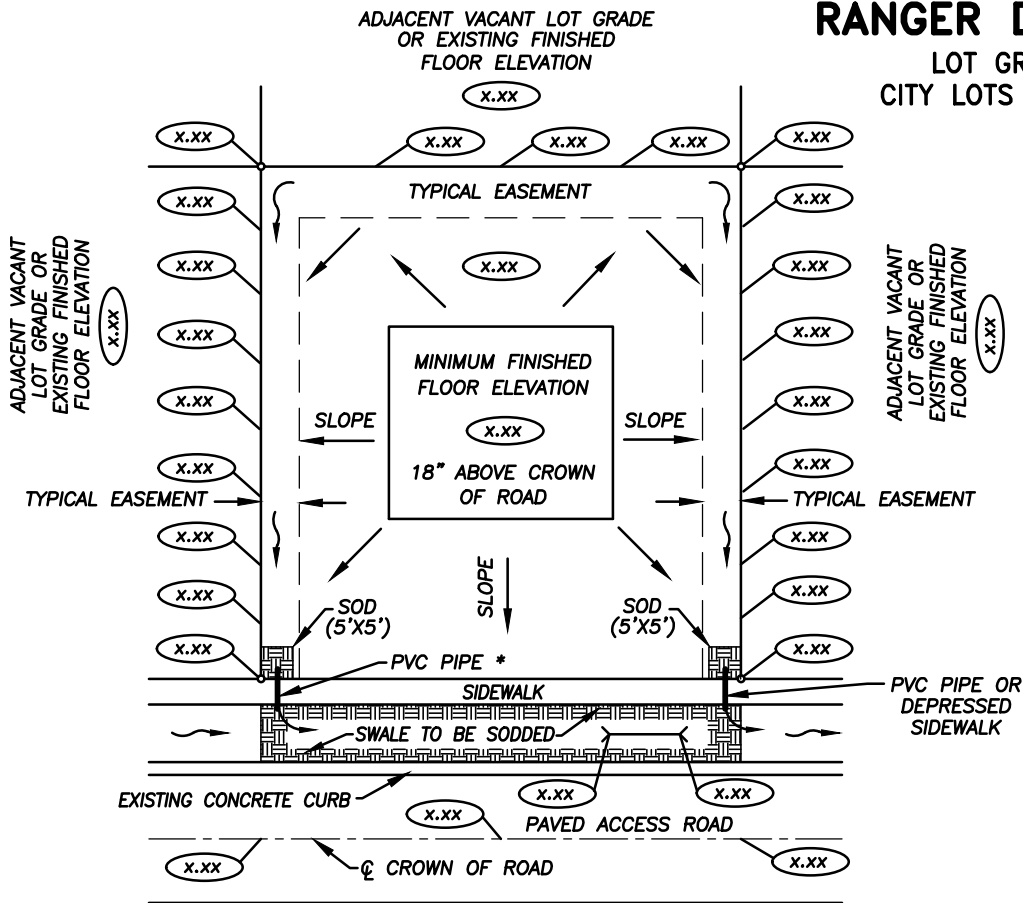

(x.xx) INDICATES REQUIRED ELEVATION OF EXISTING, PROPOSED AND ASBUILT.

NOTE:
SILT FENCES ARE REQUIRED FOR ANY LOT BEING EXCAVATED, FILLED OR CLEARED OF TREES. SEE TYPE III SILT FENCE DETAIL BELOW. THE LOCATION OF PROPOSED SILT FENCING SHALL BE DEPICTED ON ALL GRADING PLANS AND INCLUDE A SILT FENCE DETAIL AS SHOWN HEREON.

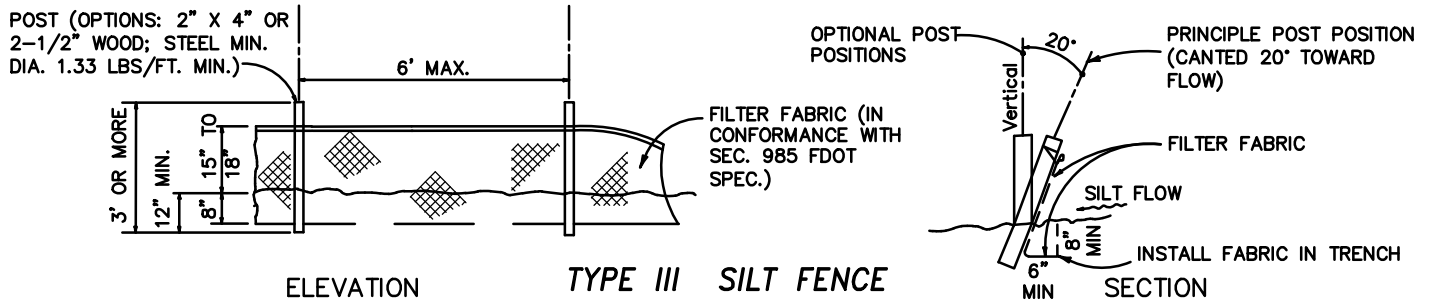

*SILT FENCE TO BE INSTALLED AND MAINTAINED AROUND PERIMETER OF LOT IN THE AREAS THAT WILL BE OR HAS BEEN CLEARED OR DISTURBED.
*SILT FENCE NEEDS TO STAY IN PLACE UNTIL THE PROJECT IS FINALIZED AND THE EARTHWORK HAS BEEN SEEDING OR SODDED.
DO NOT DEPLOY IN A MANNER THAT SILT FENCES WILL ACT AS A DAM ACROSS PERMANENT FLOWING WATERCOURSES.

NOTES:

- * PVC PIPE IF USED, REQUIRES 1-1/2 FEET MINIMUM.
- * ADJACENT LOTS (IF NOT VACANT) SHALL SHOW PATIO GRADES AND FINISHED FLOOR ELEVATIONS FOR EXISTING HOMES.
- * EXISTING TREE(S) TO REMAIN SHALL BE LOCATED AND SHOWN WITH TYPE AND TRUNK DIAMETER.
- * <—> INDICATES DRIVEWAY CULVERT. ASBUILT INVERT ELEVATIONS ARE REQUIRED. NO PAVEMENT OR CONCRETE SHALL BE INSTALLED OVER CULVERT UNTIL APPROVAL FROM THE DISTRICT.
- * ALL FACILITIES WITHIN SIDE AND REAR YARD EASEMENTS SHALL BE UNDERGROUND EXCEPT THOSE ABOVE GROUND FACILITIES AS SHALL BE PERMITTED IN WRITING.

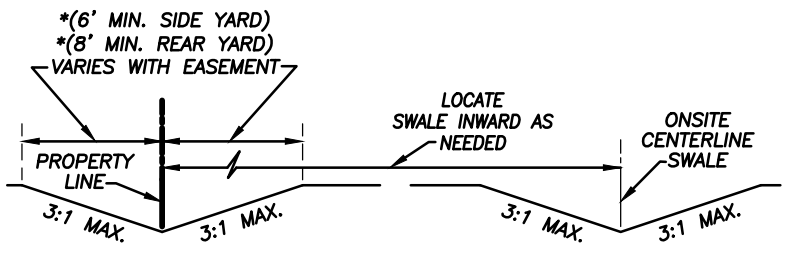

SIDE YARD SWALE SLOPE TO STREET
TYPICAL SWALE
MINIMUM EASEMENT WIDTHS PER
O.R.B. 6724, PG. 4431, ORANGE COUNTY RECORDS

DETAILS ARE NOT TO SCALE

GENERAL NOTES:

1. CENTER OF SIDE YARD SWALE TO BE LOCATED ON PROPERTY LINE. SWALES MAY BE LOCATED INWARD AWAY FROM PROPERTY LINES TO STAY CLEAR OF WETLANDS OR EXISTING TREES.
2. YARD DRAINAGE SHALL NOT DISCHARGE ON TO ADJOINING PROPERTIES.
3. SIDE SWALES SHALL HAVE POSITIVE FALL FROM REAR OF PROPERTY TO STREETS.
4. FINISHED SWALE ELEVATIONS MUST ALLOW FOR THICKNESS OF SOD.
5. A FIVE FOOT (5') SQUARE SOD AREA TO BE PLACED AT THE LOT LINE SWALE WHERE IT MEETS THE STREET. ALLOW FOR THE THICKNESS OF SOD. ROADSIDE SWALE SHALL BE SODDED TO EDGE OF PAVEMENT.

THE GRADING PLAN SHOWN HEREON ESTABLISHES MINIMUM STANDARDS FOR BUILDERS AND HOMEOWNERS OF CITY LOTS TO ASSIST PROPER DRAINAGE AWAY FROM THE RESIDENCE INTO RANGER DRAINAGE DISTRICT FACILITIES.

ACCEPTED _____
DATED: _____

